

ABS & Stainless Steel Case, Liquid Filled



900 SERIES

- High quality liquid filled gauge
- Vacuum and compound ranges through 0 psi to 15,000 psi
- 1-1/2", 2", 2-1/2" and 4" gauge sizes
- Impact-resistant ABS and Stainless Steel case
- Copper alloy and Brass wetted parts

OPERATING SPECIFICATIONS

1. Working Pressure Limitations

a. Dynamic Pressure

The working pressure should be limited to 60% of the dial range.

b. Static Pressure

The working pressure, where no sharp fluctuations occur, should be limited to 90% of the dial range

APPLICATIONS

- Automotive
- Construction
- Hydraulics & pneumatics
- Power generation
- Transportation
- Water management

	SERIES	SPECIFICATIONS
Pressure ranges	900 Series (all)	Vacuum and compound ranges through 0 psi to 15,000 psi
Accuracy	15-910	±2.5% full scale
	25-900, 25-910, 25-901, 25-911	±1.6% full scale
	40-901, 40-911	±1% full scale
Temperature ranges*	900 Series (all)	Media -4 °F to 140 °F (-20 °C to 60 °C) Glycerin fill -40 °F to 140 °F (-40 °C to 60 °C) Special fill Ambient -4 °F to 140 °F (-20 °C to 60 °C) Glycerin fill -40 °F to 140 °F (-40 °C to 60 °C) Special fill
Measuring element	900 Series (up to 600 psi)	Copper alloy C-Type Bourdon tube
	900 Series (> 600 psi)	Coiled safety tube
Connection	15-910	1/8" NPT, Brass
	25-900, 25-910, 25-901, 25-911	1/4" NPT or 7/16"-20 adjustable, Brass
	40-901, 40-911	1/4" NPT, Brass 1/2" NPT, Brass
Case	15-910, 25-900, 25-910	ABS with safety relief plug
	25-901, 25-911, 40-901, 40-911	304 Stainless Steel
Bezel	25-901, 25-911, 40-901, 40-911	304 Stainless Steel
Lens	15-910, 25-900, 25-910	Acrylic; ultrasonically welded to the case
	25-901, 25-911, 40-901	Polycarbonate
Pointer	15-910, 25-900, 25-910, 25-901, 25-911	Molded plastic
	40-901, 40-911	Balanced Aluminum, black finish
Dial	15-910, 25-900, 25-910, 25-901, 25-911	Molded plastic, white background with black primary scale & red secondary scale. UV resistant
	40-901, 40-911	Aluminum, white background with black primary scale & red secondary scale. UV resistant.
Movement	15-910, 25-900, 25-910, 25-901, 25-911	Brass and nylon with highly polished bearing surfaces
Fill liquid**	15-910	86.5/13.5 Glycerin:H ₂ O
	25-900, 25-910, 25-901, 25-911, 40-901, 40-911	Glycerin

* For every 18 °F (10 °C) shift in temperature from which the gauge is calibrated, the user can experience up to ±0.4% additional error.

**See page 51 for gauge fill options.

For details on accuracy/standard dial configuration and dial layouts, see pages 56-61.

ORDERING INFORMATION									
GAUGE SIZES	15 1-1/2"	20 2"	25 2-1/2"	40 4"					
CASE TYPES	900	ABS Case, bottom connection		910	ABS Case, back connection				
	901	SS Case, bottom connection		911	SS Case, back connection				
PRESSURE RANGES	30vac	-30 inHg to 0 psi	100	0 psi to 100 psi	5000	0 psi to 5,000 psi	10	0 bar to 10 bar	
	30/15	-30 inHg to 0 to 15 psi	160	0 psi to 160 psi	6000	0 psi to 6,000 psi	16	0 bar to 16 bar	
	30/30	-30 inHg to 0 to 30 psi	200	0 psi to 200 psi	7500	0 psi to 7,500 psi	25	0 bar to 25 bar	
	30/60	-30 inHg to 0 to 60 psi	300	0 psi to 300 psi	10000	0 psi to 10,000 psi	40	0 bar to 40 bar	
	30/100	-30 inHg to 0 to 100 psi	400	0 psi to 400 psi	15000	0 psi to 15,000 psi	60	0 bar to 60 bar	
	30/160	-30 inHg to 0 to 160 psi	600	0 psi to 600 psi	-1	-1 bar to 0 bar ^{††}	100	0 bar to 100 bar ^{††}	
	30/200	-30 inHg to 0 to 200 psi	800	0 psi to 800 psi	1	0 bar to 1 bar ^{††}	160	0 bar to 160 bar ^{††}	
	30/300	-30 inHg to 0 to 300 psi	1000	0 psi to 1,000 psi	1.6	0 bar to 1.6 bar ^{††}	250	0 bar to 250 bar ^{††}	
	15	0 psi to 15 psi	1500	0 psi to 1,500 psi	2.5	0 bar to 2.5 bar ^{††}	400	0 bar to 400 bar ^{††}	
	30	0 psi to 30 psi	2000	0 psi to 2,000 psi	4	0 bar to 4 bar ^{††}	600	0 bar to 600 bar ^{††}	
	60	0 psi to 60 psi	3000	0 psi to 3,000 psi	6	0 bar to 6 bar ^{††}	1000	0 bar to 1,000 bar ^{††}	
	SCALE OPTIONS	psi	psi single scale	psi/kg/cm ²	psi/kg/cm ² dual scale	bar/psi	bar/psi dual scale	psi/kPa	psi/kPa dual scale
		psi/bar	psi/bar dual scale						
CONNECTION SIZES	1/8 1/8" NPT	1/4 1/4" NPT	1/2 1/2" NPT	SST	SAE J1926-3:7/16-20 Adjustable *				
OPTIONS	PMC	Steel Panel Mount Clamp	SSCR	304SS Cover Ring	BLFF	Black Front Flange ^{***}	ST	Stainless Steel Tagging	
	SPMC	304SS Panel Mount Clamp	MIP	Maximum Indicating Pointer ^{**}	SSFF	304SS Front Flange [†]	BP3	Brass Press Fit Orifice 0.3 mm	
	SSBU	Stainless Steel Bezel & U-clamp	SP	Red Set Pointer	SSRF	304SS Rear Flange	BT5	Brass Threaded Orifice 0.5 mm	
	SSB	Stainless Steel Bezel	SG	Safety Glass Lens	LM	Laser Marking	BT8	Brass Threaded Orifice 0.8 mm	

Please consult your local NOSHOK Distributor or NOSHOK, Inc. for availability and delivery information.

NOTES: Refer to 900 Series Options & Accessories chart on page 53 for availability by series number.

Cleaning for Oxygen Service (O2) is available only for dry or HL filled gauges

* Includes FKM o-ring

** GY40 fill is standard for liquid filled gauges

*** Black Front Flange is only available for 25-910 gauges

† Stainless Steel Front Flange is not available for the 901 case type

†† Standard with G1/4 process connection

EXAMPLE

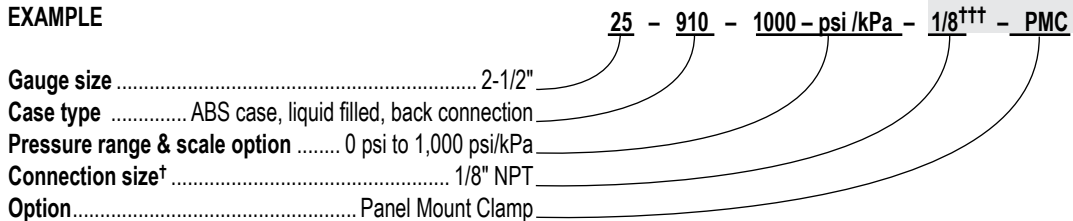

††† Only include in part number if non-standard connection size is ordered.

NOTES: See standard connection sizes chart on page 49.

Shaded portions of this part number example are not required unless a non-standard connection size or an option is needed.

25-900

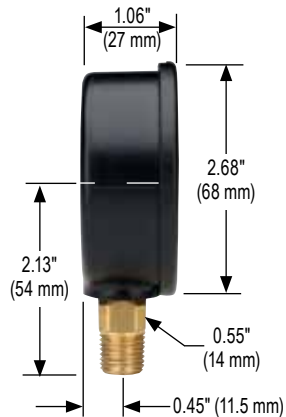

25-910



Dimensions

15-910

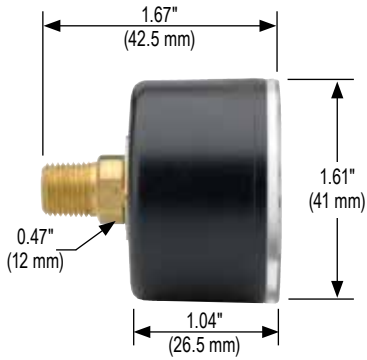

25-910

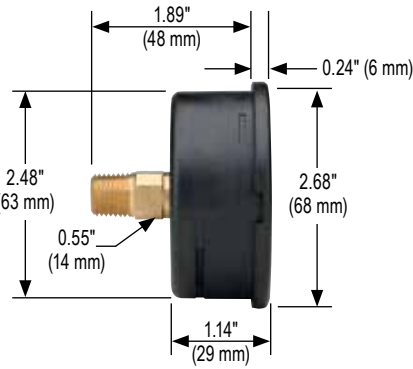

25-911

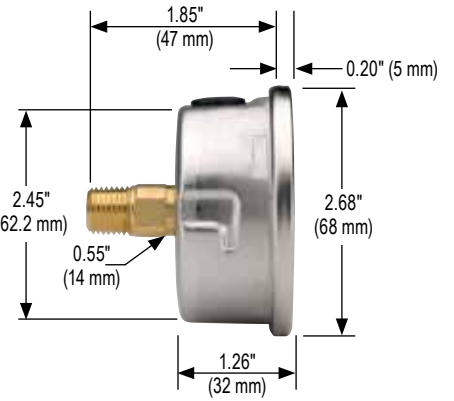

40-901

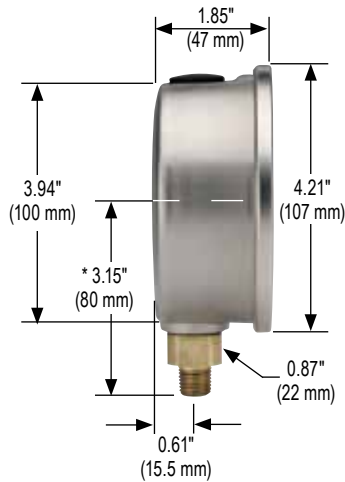

* 1/4" NPT shown
Add 6 mm for 1/2" NPT

40-911

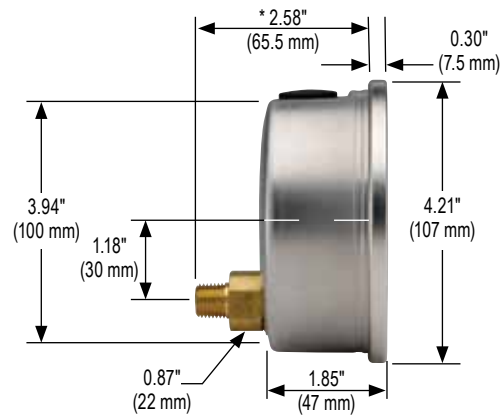

25-910 Front Flange

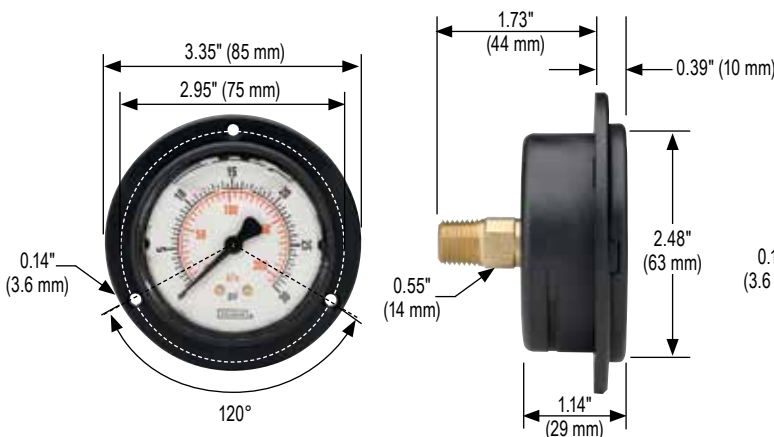

25-911 Front Flange

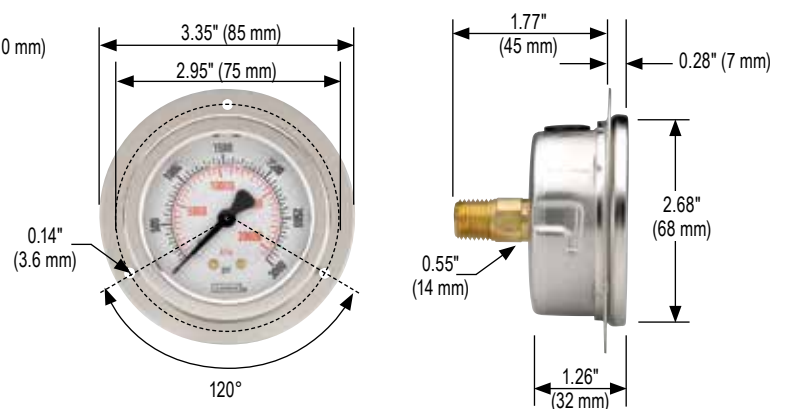

40-911 Front Flange

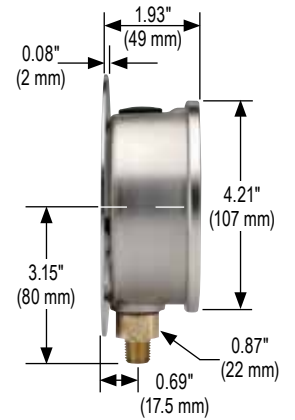
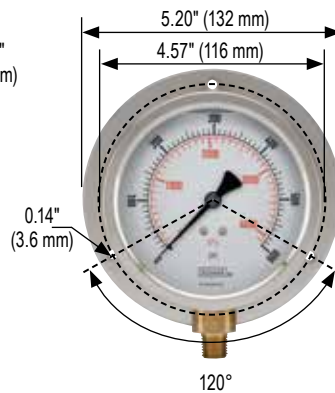
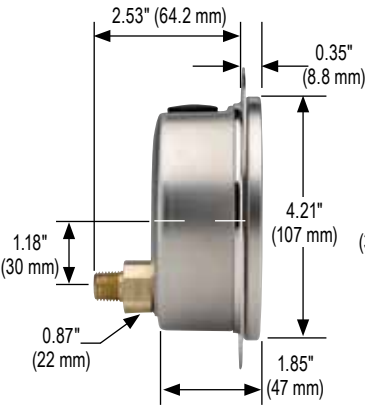
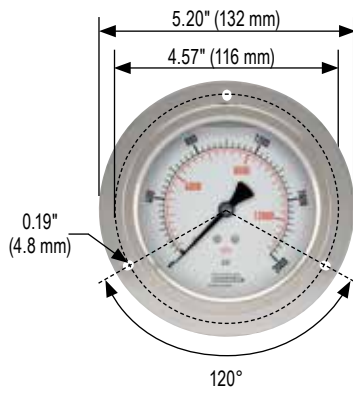

40-911 Rear Flange

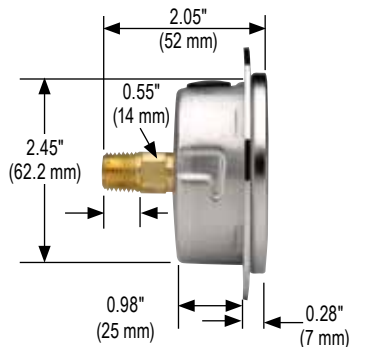
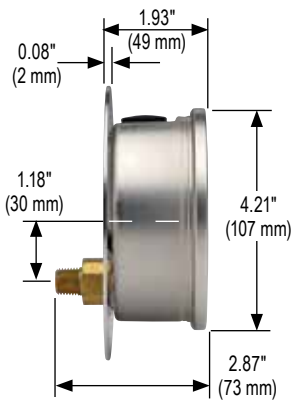
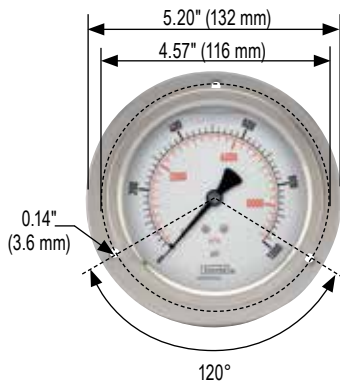

25-910 Panel Mount Clamp

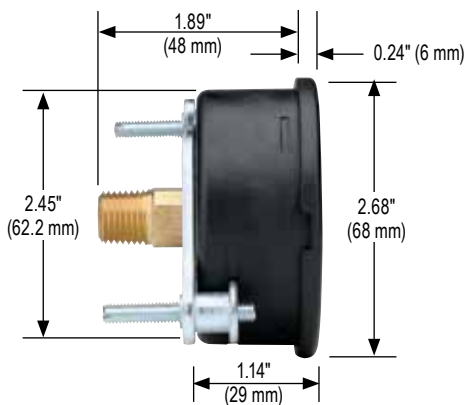

25-911 Panel Mount Clamp

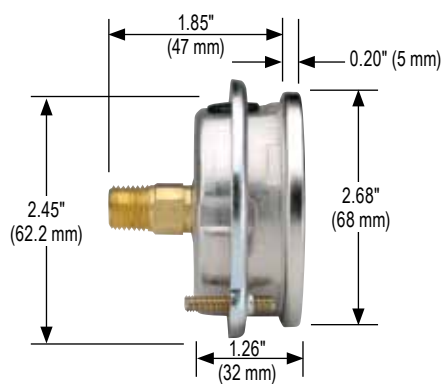

40-911 SS Narrow Bezel w/U-Clamp

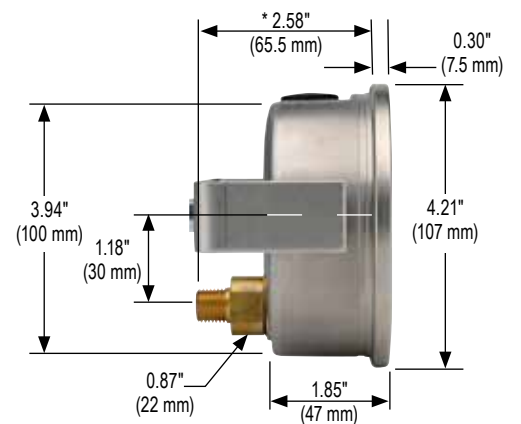

* 1/4" NPT shown. Add 6 mm for 1/2" NPT. 33