

# Air-Guard Dual Stage Filter 60 SCFM

## 9460 SERIES



- Designed for main supply line applications where pipe scale, residual oil aerosols, and condensation can degrade air quality
- Dual cartridge design provides long service life
- Supplied with KING Type 750/800 element set that includes coalescing scrubber and adsorptive polisher cartridges, Type 300/300 element set is optional

### SPECIFICATIONS

Maximum pressure	150 psi
Rated flow	60 scfm @ 100 psig; 1699 l/min @ 7 Kg/cm <sup>2</sup> ; 102 m <sup>3</sup> /hr @ 7 bar
Connections	1" NPT
Filter type	Dual cartridge coalescing elements
Housing	Aluminum
Sump	Aluminum
Efficiency	99.998% @ 0.1 micron
Weight	25.0 lb/11.3 kg

### APPLICATIONS

- Main supply line applications where pipe scale, residual oil aerosols, and condensation can degrade air quality

ORDERING INFORMATION		
SERIES	9460 Air-Guard Dual Stage Filter 60 SCFM	
DRAIN TYPES	3 With manual drain	3T With auto drain
EFFICIENCY	6-5 99.998% @ 0.1 micron	1-1 98% @ 2.0 micron

**EXAMPLE**

Series .....9460 Series  
 Drain type ..... With auto drain  
 Efficiency ..... 98% @ 2.0 micron

**9460 - 3T - 1-1**

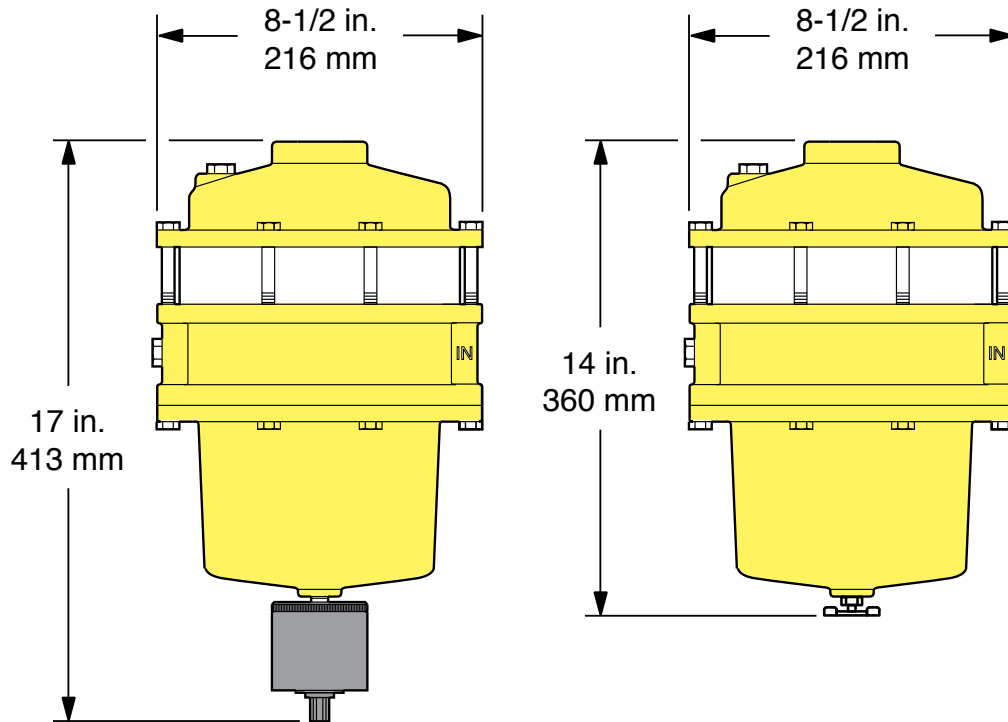

Replacement Cartridge Sets
22-31-6-5 - Type 750/800 (0.1 micron)
22-31-1-1 - Type 300/300 (2.0 micron)