

Air-Guard Dual Stage Filter 100 SCFM



2260 SERIES

- 100 scfm flow rating offers high efficiency coalescing action to deliver clean, dry, and oil-free air
- Ideal for installation in main distribution air piping to remove residual oil, condensed water, and abrasive particulates
- Dual cartridge design provides long service life
- Supplied with KING Type 750/800 element set that includes coalescing scrubber and adsorptive polisher cartridges, Type 300/300 element set is optional

SPECIFICATIONS

Maximum pressure	150 psi
Rated flow	100 scfm @ 100 psig; 2832 l/min @ 7 Kg/cm ² ; 170 m ³ /hr @ 7 bar
Connections	1" NPT
Filter type	Dual cartridge coalescing elements
Housing	Aluminum
Efficiency	99.998% @ 0.1 micron
Weight	30.0 lb/13.6 kg

APPLICATIONS

- Main distribution air piping to remove residual oil, condensed water, and abrasive particulates

ORDERING INFORMATION		
SERIES	2160 Air-Guard Dual Stage Filter 100 SCFM	
DRAIN TYPES	1 With manual drain	1T With auto drain
EFFICIENCY	1-1 98% @ 2.0 micron	6-5 99.998% @ 0.1 micron

EXAMPLE

Series2160 Series
 Drain type.....With manual drain
 Efficiency.....99.998% @ 0.1 micron

2160 - 1 - 6-5

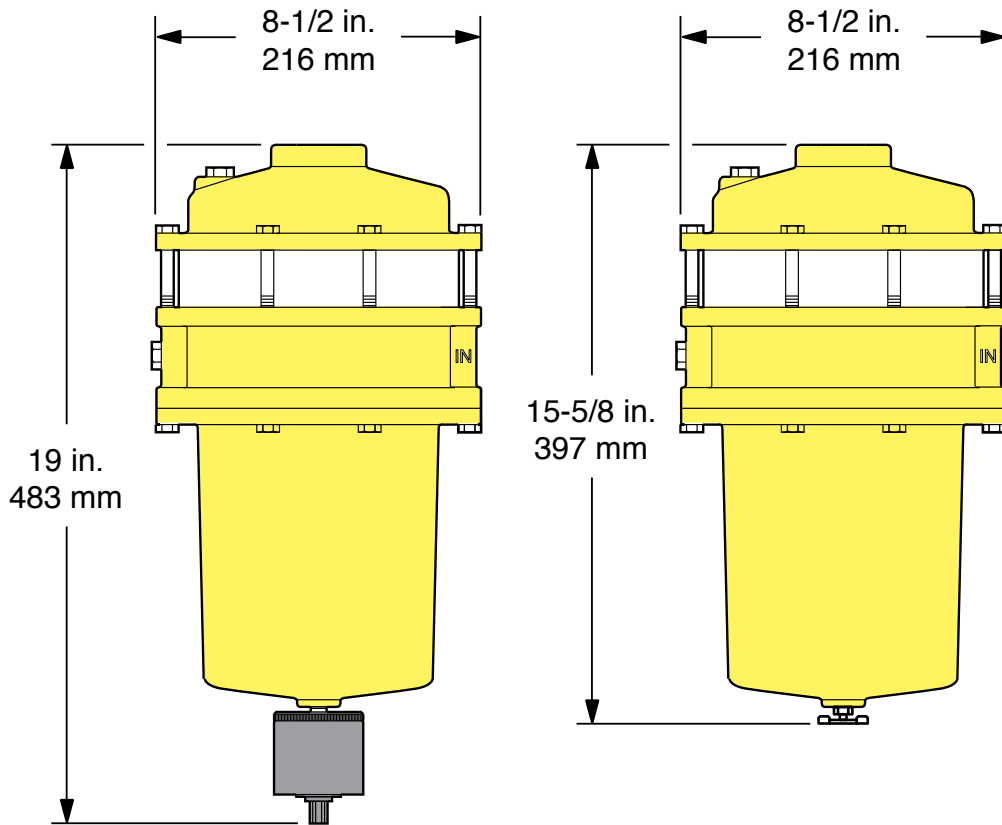

Replacement Cartridge Sets
A22-51-6-5 - Type 750/800 (0.1 micron)
A22-51-1-1 - Type 300/300 (2.0 micron)